

Electromagnetic Locks AEL0222 / AEL0242

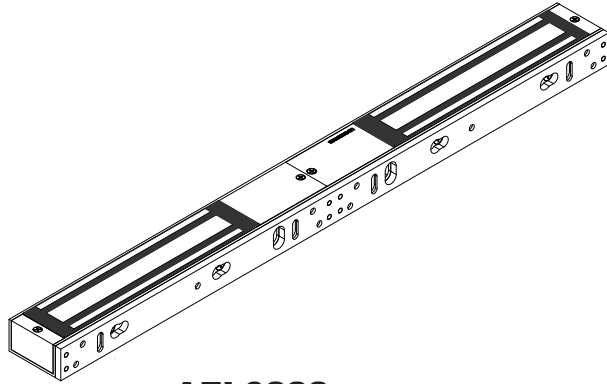

Description

The Electromagnetic Lock (Maglock) is a surface mounted magnetic lock assembly. It is a narrow profile model available in single lock format with various sizes (force) designed for standard installation on most types of doors.



AEL0222

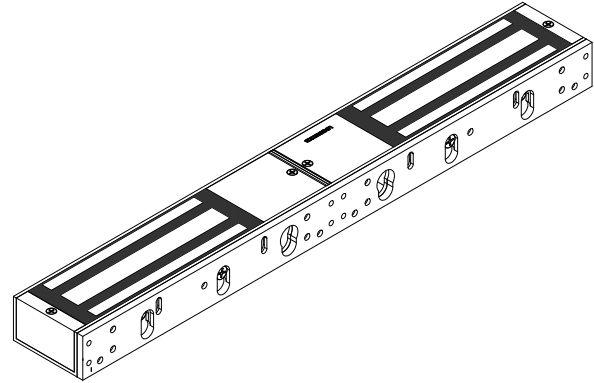

AEL0242

Specifications

DESCRIPTION	AEL0222	AEL0242
Holding Force (lbs)	600	1200
Lock	Double	Double
Input Voltage (VDC)	12 to 24	12 to 24
Current Draw: @ 12 VDC (amps) @ 24 VDC (amps)	1.000 0.500	1.000 0.500
Relay Rating: (resistive) @ 24 VDC (amps)	1.0	1.0
Material: Lock Housing Armature / Strike Plate	Aluminum Zinc Plated Steel	Aluminum Zinc Plated Steel
Additional Features:	Inbuilt Door Status Monitor	Inbuilt Door Status Monitor

Precautions

⚠ CAUTION

- Shut off all power before attempting any wiring procedures.
- Maintain a clean & safe environment when working in public areas.
- Constantly be aware of pedestrian traffic around the door area.
- Always stop pedestrian traffic through the doorway when performing tests that may result in unexpected reactions by the door.
- Always check placement of all wiring before powering up to insure moving door parts will not catch any wires and cause damage to equipment.
- Ensure compliance with all applicable safety standards and building codes upon completion of installation.

⚠ WARNING

Warnings indicate potentially hazardous conditions, which if not avoided or corrected, may cause death or serious injury.

⚠ CAUTION

Cautions indicate potentially hazardous conditions, which if not avoided or corrected, may cause minor or moderate injury. Cautions may also warn against unsafe practices.

NOTICE

Notices indicate a condition that may cause equipment or property damage only.

SI Support Service

support@ipixa.co.uk www.ipixa.co.uk

Electromagnetic Locks AEL0222 / AEL0242



NOTICE

1. The product should only be powered by an Manufacture Approved power supply
2. Relay output is designated as Common.
3. Same Room Install – Resistive.
4. Installation Location: Indoor
 - Installation & wiring in compliance with International Building Codes requirements
 - Wiring must be cased to avoid outer cable damaged, affect the insulation distance
 - Terminal: 12~22AWG
5. If power switch is not wired between DC source voltage and magnet, it will take a longer time to de-energize the magnet simulating residual magnetism.(see below)

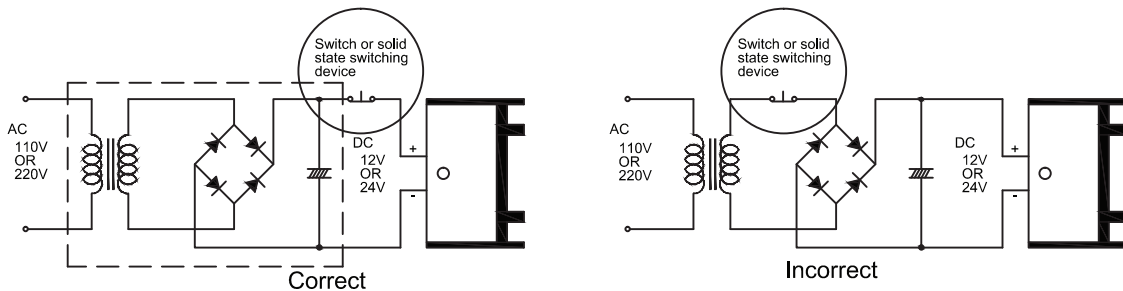

Printed Circuit Board Schematic

Installation Tips

1. DO NOT touch the lock face with your hands.
2. Should the surface plating be damaged, use a soft, clean dry cloth or abrasive cloth to clean the lock face. DO NOT use sand paper. A rust inhibitor can be applied to the armature/strike plate and maglock assembly face.

SI Support Service

support@ipixa.co.uk www.ipixa.co.uk

Electromagnetic Locks AEL0222 / AEL0242



Installation - Electrical

1. Position the jumpers according to the input voltage, and then finish electrical connection to the door operator.
2. When the maglock assembly and armature/strike plate are mated, the junction is Normally Open and the LED will turn to green.
3. The remaining three terminals of the terminal block (COM/ NO/ NC) provide an auxiliary relay output which can be used as a door position switch.

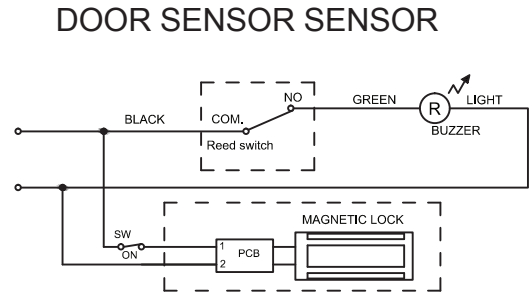
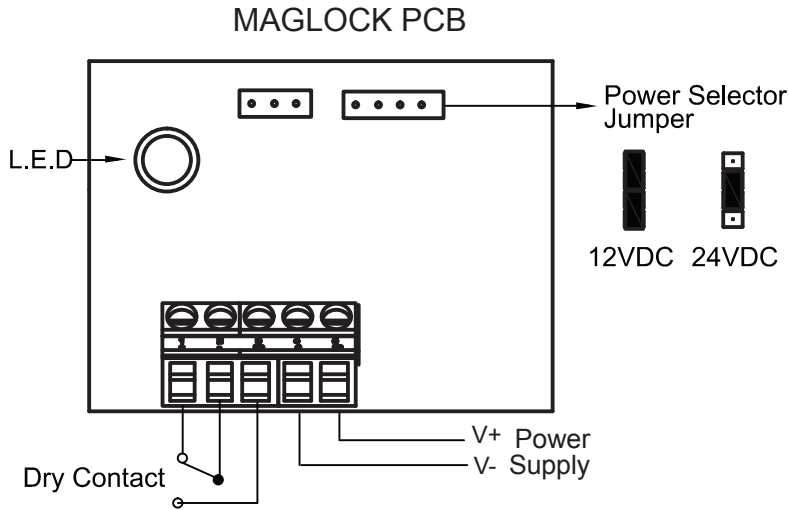

* When "SW" is OFF, the Door Status Sensor (REED SWITCH) detects if the door is well closed.

CAUTION
Unit may work if jumpers are incorrectly installed, but will draw a higher current and may possibly damage the assembly.

DOOR SENSOR (Reed SW.)

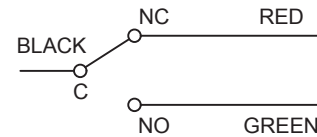

Reed switch dry contacts are rated max 3w (max switching contact 0.25 A) for safe operation. Do not exceed the rating.

Typical Installation

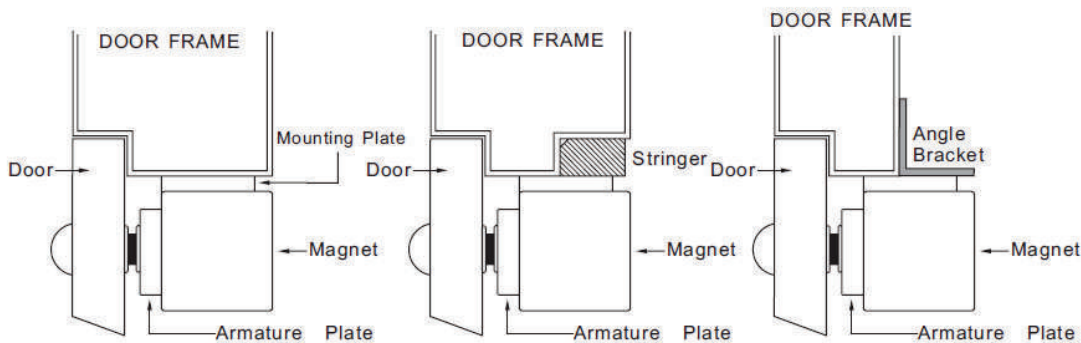

** Important: Fix the armature plate not too tightly and make the rubber washer more flexible in order to make the armature plate automatically adjust its proper position with the magnet

Electromagnetic Locks AEL0222 / AEL0242



Installation - Mechanical

1. Inspect the frame header to determine if an angle bracket or filler plate is required.
2. Use the paper pattern template to mark and drill holes as indicated.
3. Disassemble the mounting plate from the maglock assembly using hex key Insert 2 screws into the slotted holes and secure the mounting plate to the doorframe using two of mounting screws. Do not tighten these screws fully until the maglock is properly aligned.
4. Gently spring pins into the rear side of the armature Drill matching holes on the door to receive these pins.
5. Align armature/strike plate to magnet, and then drill hole in door for sexnut and aluminum reinforcement tube for hollow doors. Using the hex head screw and hex key mount armature to door using washers.
6. Continue to fasten mounting plate to heading using remaining screws. Then, reassemble maglock assembly to mounting plate.
7. Route the enclosed wiring harness through the rectangular hole in the mounting plate. Make the electrical connection as shown below.
8. Make sure that armature/strike plate can be shaken slightly. This will permit full armature contact and maximize holding force.

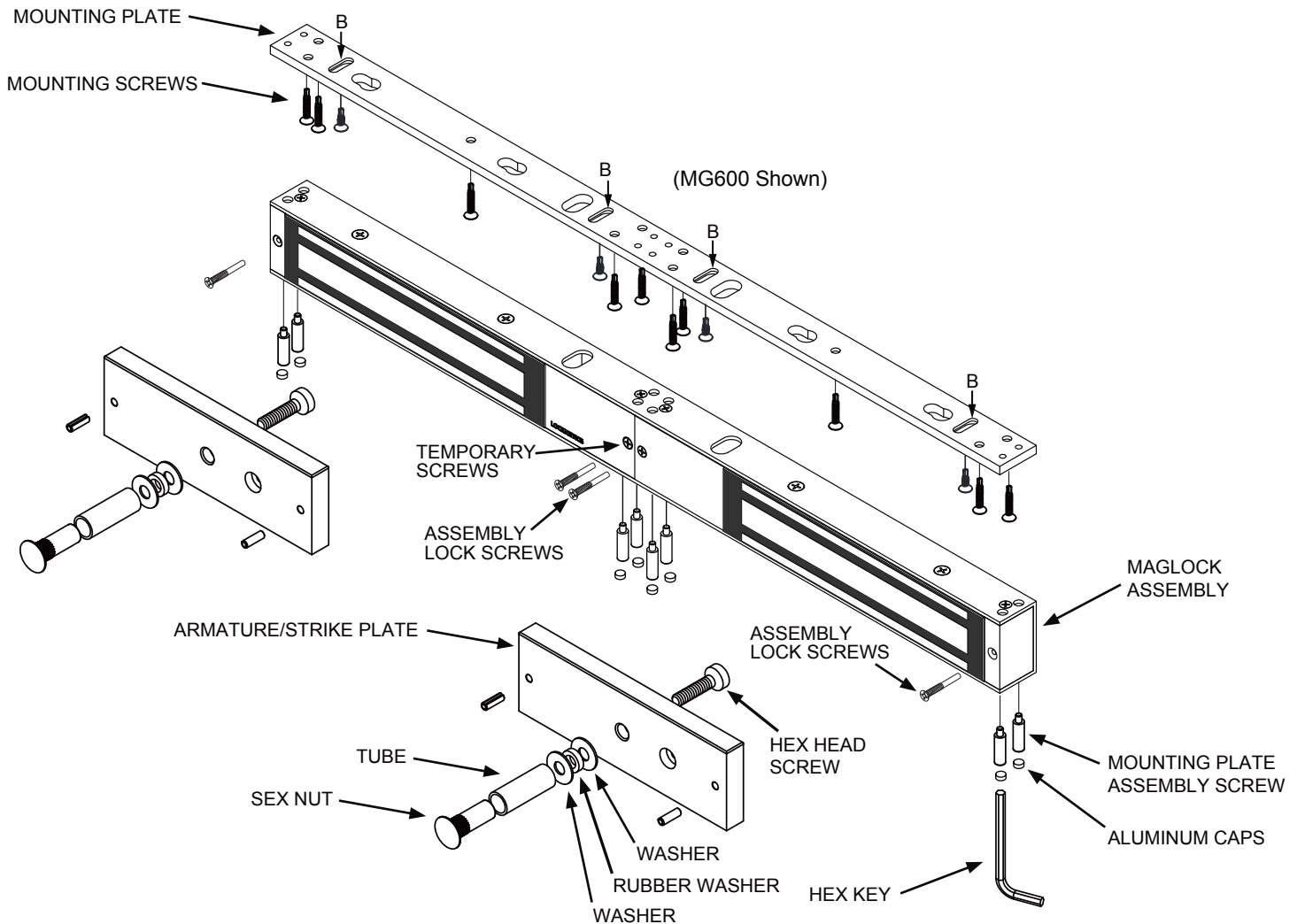

SI Support Service

support@ipixa.co.uk www.ipixa.co.uk