

Electrified Power Bolt AEL0201.GF

Description

The AEL0201.GF Electrified Power Bolt (Electric Drop Bolt) is a drop bolt lock assembly for fully frameless glass doors.

Installation

Steps:

Clean the glass surface & mark the position where the power bolt is intended to be installed

Fix the spacer inside the U bracket, quantity of space can be increased according to the thickness of glass

Use the double sided tape and fix the brackets on the glass

Tighten the brackets using the Allen Key provided

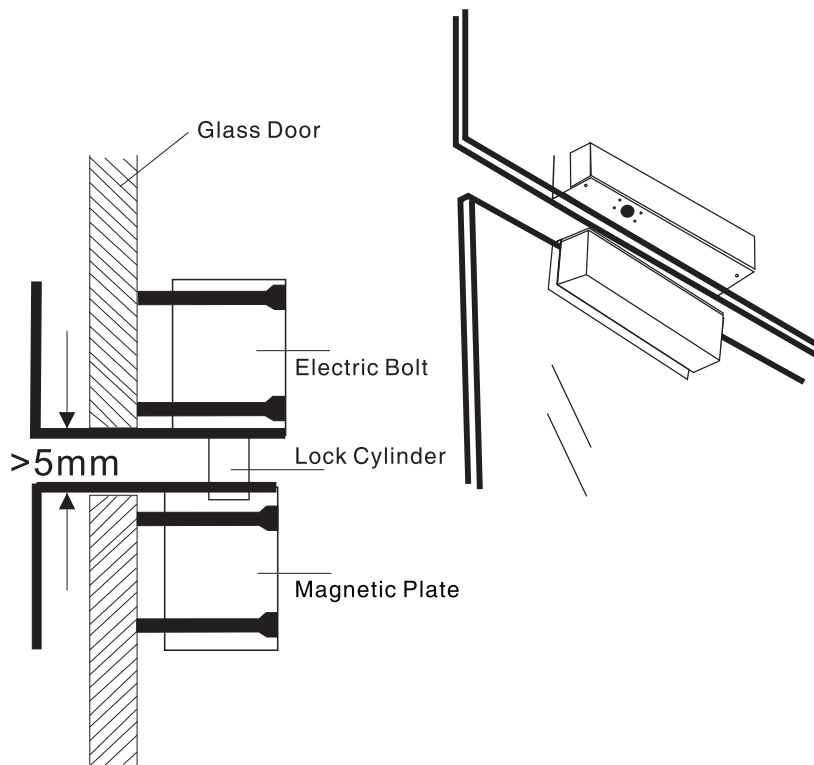

Note:

AEL0201.GF power bolt is specially designed for 180 degree in-swing and out-swing or sliding glass doors

The thickness of glass door is 10-14mm

The gap between the bracket & the electric bolt is 5-8mm

Wiring Diagram

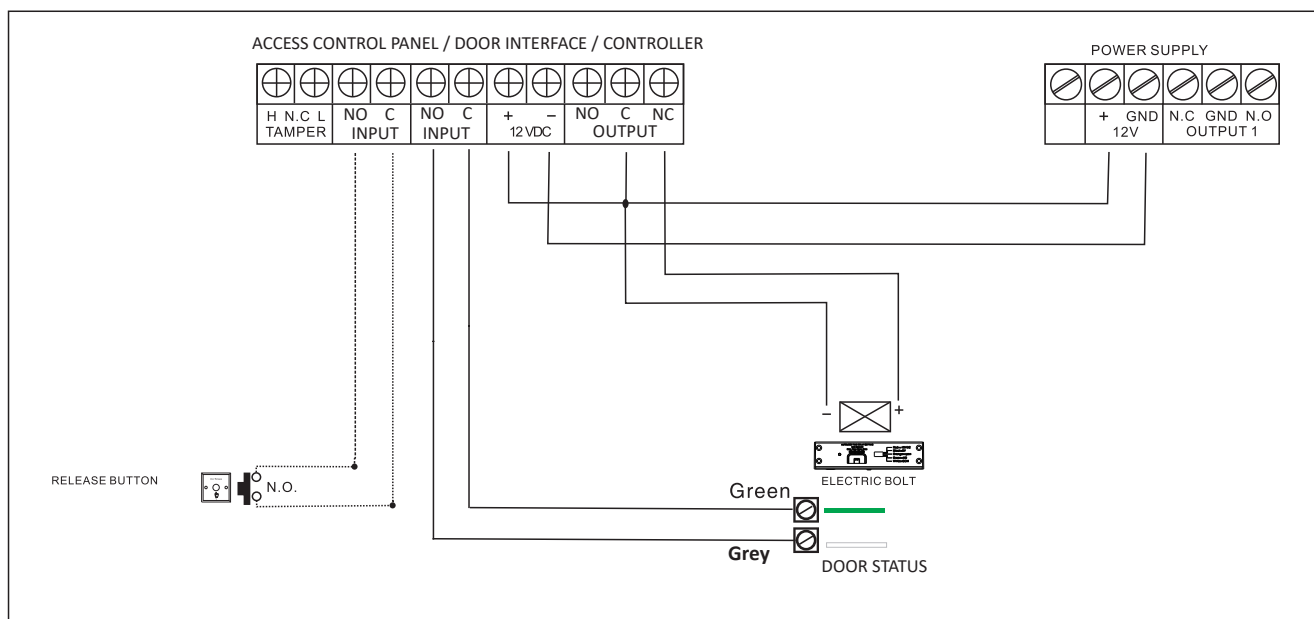

SI Support Service

support@ipixa.co.uk www.ipixa.co.uk